

GJD 4 Zone Expansion Unit

GJD040

Installation Instructions

The 4 Zone Expansion Unit works in conjunction with DygiZone lighting controllers, Solitaire Touch Controls and GJD detection devices. The modular design enables the 4 Zone Expansion Unit to be conveniently installed within easy access to the mains supply. The low voltage cable link allows the DygiZone lighting controllers, Solitaire Touch Controls and Expansion Units to be positioned anywhere up to a distance of 200 metres.

4 Zone Expansion Unit Specifications

Mains Supply Input	2 x 230 VAC 50 HZ VIA RCD, MCB and 13 AMP Fused Spurs
Lighting Outputs Driven	4 x 230 VAC 50 HZ 1500 Watts Maximum or 1000 Watts Ballast Inductive loads may require a "snubber" (suppressor) to manage the lamp discharge current.
12 VDC Output	12 VDC @ 1 AMP
'T' 1&2 Output	25mA +VE Suitable for driving base of NPN transistor. Triggered from detectors on Zones 1 & 2
'T' 3&4 Output	25 mA +VE Suitable for drivign base of NPN transistor. Triggered from detectors on Zones 3 & 4
AUX 1&2 Output	50 mA -VE Suitable for driving low power sounders. Triggered from detectors on Zones 3 & 4
AUX 3&4 Output	50 mA -VE Suitable for driving low power sounders. Triggered from detectors on Zones 3 & 4
Options	Up to 10 Expansion Units can be added to a system for additional switching capacity or 12 volt supply
Operating Temperature	-10 to +50 Centigrade
Weight	810gms
Dimensions	210 x 180 x 79mm
	Class 2 Independently mounted control EMC Directive 2004/108/EC

Important Safety Requirements

The 4 Zone Expansion Unit **MUST** be installed and maintained by suitably qualified engineers and the installation **MUST** comply with all relevant codes of practice and regulations. All mains supplies to the 4 Zone Expansion Unit **MUST** be via Residual Current Device/s (RCD) and overload protection device/s.

All mains supplies to the 4 Zone Expansion Unit **MUST** be disconnected before removing the cover.

230 VAC Supply

The 4 Zone Expansion Unit requires 230 VAC supply on to the top LIVE input and a neutral on to one of the N connections on the top neutral terminal block, this provides power for the unit to operate and for the lighting outputs L1 and L2.

The bottom LIVE input requires a 230 VAC supply to provide power for the lighting outputs L3 and L4.

WARNING: BOTH OF THESE SUPPLIED MUST BE ON THE SAME PHASE

230 VAC Lighting Outputs

These are four 230 VAC switched live outputs L1, L2, L3 and L4 for controlling lighting, each output has a maximum switching capacity of 1500 watts for incandescent lighting of 1000 watts for ballast driven lighting.

All of the Neutral 'N' connections are linked together on the top neutral terminal block.

All of the Neutral 'N' connections are linked together on the bottom neutral terminal block.

An earth connection block is provided for the termination of all earth conductors.

Low Voltage Inputs

The C,D and E connections are the clock and data lines that communicate with the low voltage DygiZone and Solitaire controllers.

The A and S connections are negative applied/removed trigger inputs from GJD detectors.

Low Voltage Outputs

The 4 Zone Expansion Unit has a 12 VDC 1 Amp output to provide power for controllers and detectors.

T 1 & 2 Outputs

The T 1&2 output is a switched positive output maximum of 12 VDC @ 25mA. This is suitable for triggering a transistorised relay. The output becomes active when a detector is triggered and the audio is selected in zones 1 and 2 respectively. The output remains active for the pre set time that is selected on the controller.

T 3 & 4 Output

The T 3&4 output is a switched positive output maximum of 12 VDC @ 25 mA. This is suitable for triggering a transistorised relay. The output becomes active when a detector is triggered and the audio is selected in zones 3 and 4 respectively. The output remains active for the pre set time that is selected on the controller.

AUX 1 & 2 Output

The AUX 1 & 2 output is a switched negative output maximum of 50mA. This is suitable for powering a piezo sounder. The output becomes active when a detector is triggered and the audio is selected in zones 1 and 2 respectively. This output will produce the same tone as the beep output on the controller.

AUX 3 & 4

The AUX 3&4 output is a switched negative output maximum of 50mA. This is suitable for powering a piezo sounder. The output becomes active when a detector is triggered and the audio is selected in zones 3 and 4 respectively. This output will produce the same tone as the beep output on the controller.

GJD Expansion Unit and Keypad Interconnecting Cable Recommendations

When using 2 or 4 zone Expansion Units and DygiZone keypads Cat5, Cat6 or any twisted pair cable must not be used to interconnect Expansion Units and keypads. Standard alarm cable is recommended.

Consideration must also be given to cable lengths due to voltage drop along the cable. When the volt drop exceeds the equipment's working range it will be necessary to either fit additional power supplies ensuring the 0 volt lines are linked together or use additional cores for the + and -. If the spanner symbol is showing steadily on the DygiZone keypad display then the voltage supply is out of range and must be checked. If the spanner symbol shows when the DygiZone is being triggered this is also showing that the voltage supply is out of range and must be checked.

If the spanner symbol is flashing on and off approximately once a second this is showing that the keypad is locked, pressing 1 and 4 at the same time for 2 seconds will unlock the keypad.

Example Voltage Drop

1 x DygiZone on 100 metres of alarm cable is approximately 1.5 volts depending on cable specifications.

1 x DygiZone on 200 metres of alarm cable is approximately 3 volts depending on cable specifications.

4 ZONE EXPANSION UNIT WIRING DIAGRAM

WARNING
DISCONNECT ALL
MAINS SUPPLIES
BEFORE REMOVING
COVER

ACTIVATE LIGHTS
FROM ALARM
PANEL

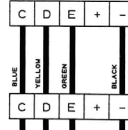

ADDITIONAL 4 ZONE
EXPANSION UNITS

DYOIZONE / SOLITAIRE
LIGHTING CONTROLLERS
MASTER SLAVE SLAVE

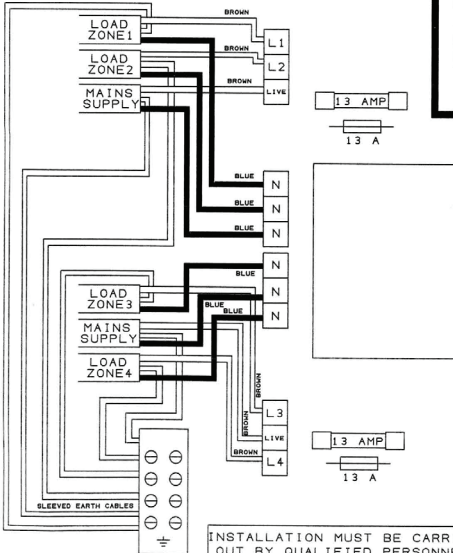

INSTALLATION MUST BE CARRIED
OUT BY QUALIFIED PERSONNEL
AND COMPLY WITH CURRENT
IEE REGULATIONS

GDJ RESERVE THE RIGHT TO AMEND
SPECIFICATIONS WITHOUT PRIOR NOTICE

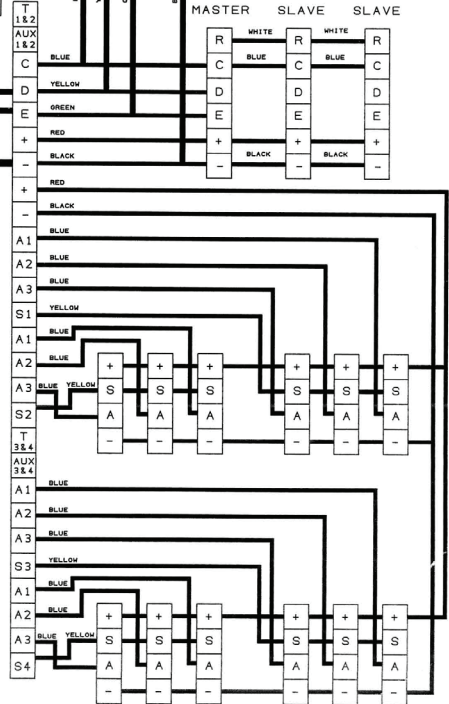

www.gjd.co.uk
technical: 01706 363990
sales: 01706 363998
fax: 01706 363991